

CBP Field Operations Enhanced Cargo Security

CBP-ADEPT-04

August 18, 2022

Mike Denning

Border-Logic Advisory Services, LLC

Phone: 678-735-0465

mdenning@mac.com

So What? Who Cares?

- CBP's need to further automate cargo security processes to screen, inspect and interdict illegal and illicit goods
- Gain greater operational effectiveness with ever-increasing trade volumes across all modes of transportation
- Create new infrastructure for maximizing available frontline officer's capabilities
- Extending trusted trader programs for closer cooperation with foreign partners
- Gain earlier visibility into worldwide supply chains
- Further integration of CBP enforcement systems

Port of Savannah Remote Operations

- Establishes Remote Operations capability
- Efficiency of CBP operations
- Workforce Multiplier
- Opportunity for increased inspection rates
- Earlier visibility into supply chain if synched with foreign partners
- Technology implemented by L3/Leidos
- Status: Fully Implemented



Primary POE – Savannah, GA

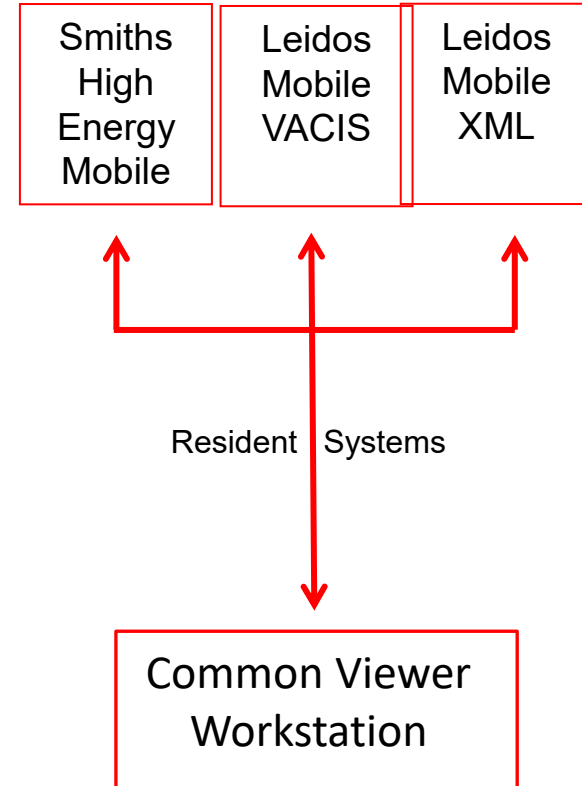

Savannah Command Center



- Remote NII Images in Common Viewer
- Remote Radiological Screening
- Visual radiological alerts from all terminal exit points
- Remote Exit Gate Controls
- Audio/Video monitoring of truck movements with driver communications
- Status: Fully implemented and operating for over 3-years at the port.

Conceptual Expanded Remote Operations East Coast Seaports

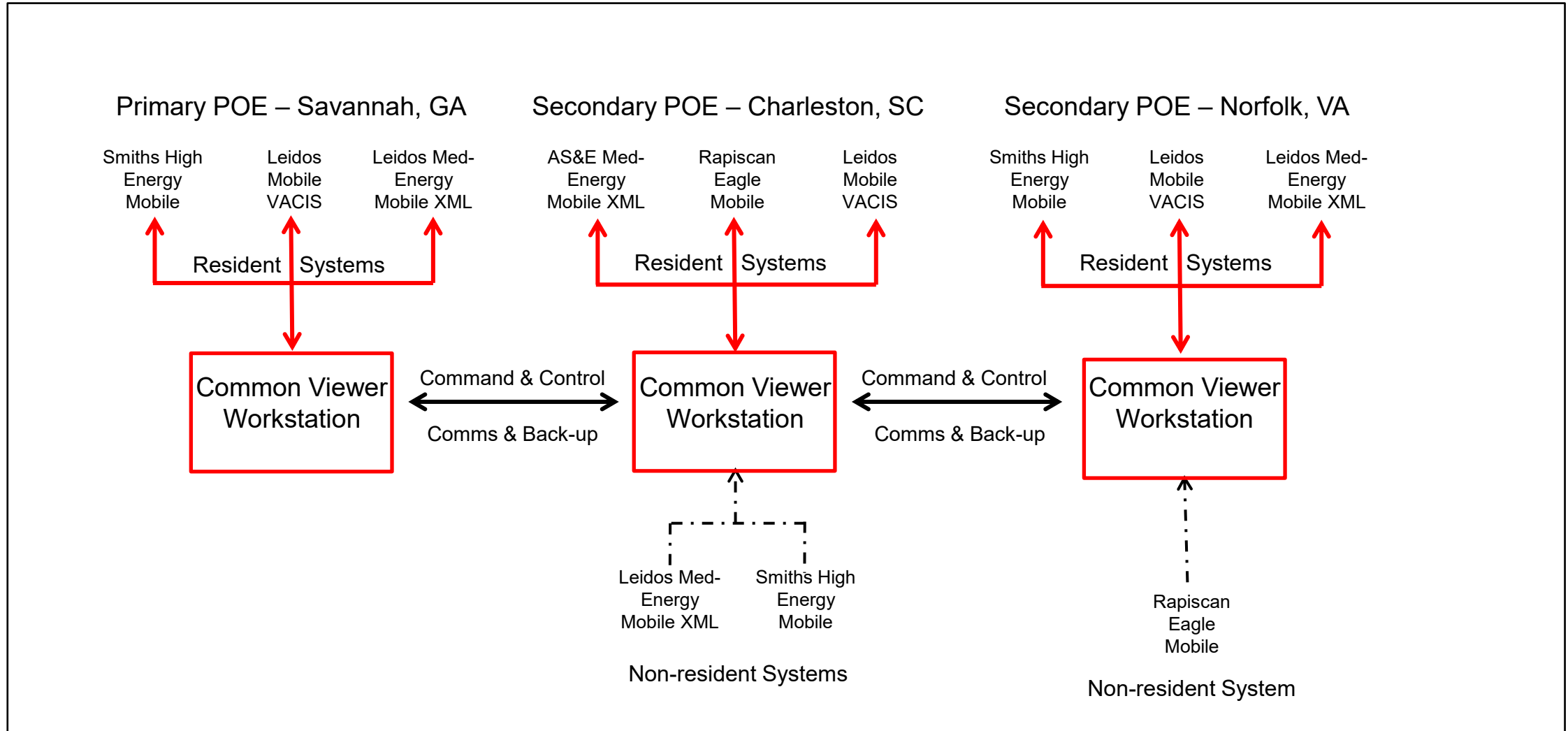

CONOP for Remote Ops in Air Environment

- Ongoing work with Delta airlines on a CONOP to transmit small scale NII images of checked luggage to CBP/TSA.
- Advanced screening and inspection of U.S. bound international baggage.
- Combined advanced NII images with APIS data for earlier CBP enforcement decisions.
- Synchronizes baggage automation with ongoing passenger modernization efforts.
- Facilitates international baggage transiting to connecting flights.
- Status: Successful technology demonstration completed in 2022.



Remote Ops in Mail and E-Commerce

- Limited advanced electronic information currently available for international mail
- More than 1.5million express consignment packages arrive daily just in Memphis, TN
- UPS Worldport handles over 4 million packages daily in Louisville, KY
- E-Commerce has reshaped global trade and narcotics enforcement efforts.
- Intellectual Property Rights challenges
- Status: Conceptual CONOP for mail and express consignment modes



Lessons Learned

- Design, development and implementation must be done in close coordination with relevant national CBP cargo policy divisions.
- Migrating the wireless transmission of NII images to a cloud-based solution is critical to expanded benefits.
- Bringing the CBP Trusted Trader team into the development effort is crucial for future expansion.
- Ensuring closer industry partnership for tighter government to business processes.
- Explore privatization for the purchase and maintenance of cargo security screening technologies.