

---

# High Energy X-Ray Sources and Detectors

Gongyin Chen and David Nisius  
Varian Medical Systems

Presented to ADSA11, Nov 4-5, Boston, MA

# Conclusion and Presentation Outline

---

**Conclusion:** Appropriate high energy x-ray sources and detectors are available and systems can be built to facilitate automatic explosive detection in air cargo.

## Outline

- Explosive material signature and detection with x-rays
- High energy x-ray sources: introduction and availability
- High energy x-ray detectors used in cargo inspection
- Effective Z determination with dual high energy x-rays
- CT systems for explosive detection in air cargo
- Varian's new high energy x-ray sources and detectors

# Explosive Signatures and Measures

- **Density:** single energy x-ray CT
- **Effective Z:** dual energy x-ray (DR or CT)

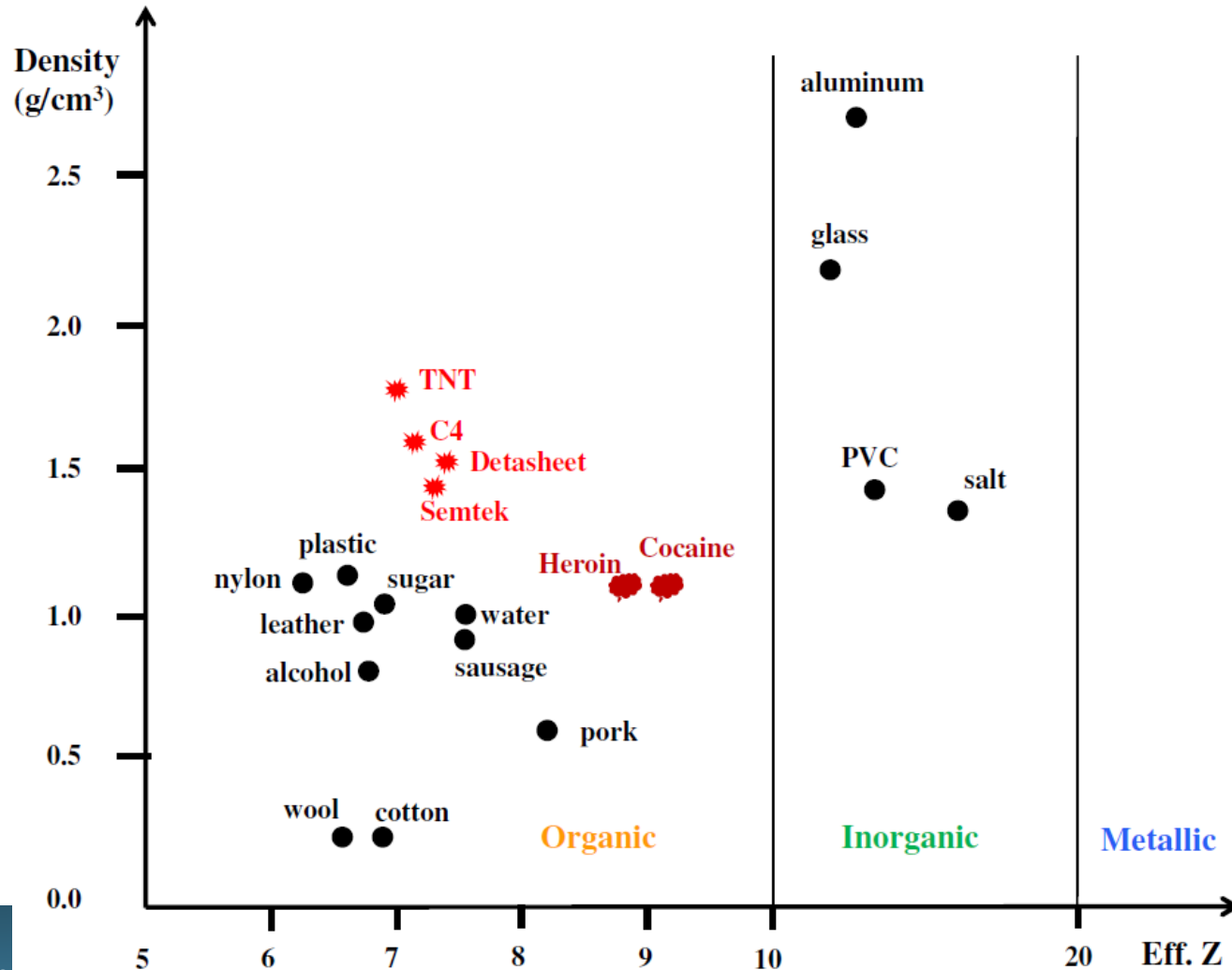

# Dual Energy X-Ray Radiography for Checked Bags

---

- Single view or multi view projection images with typical X-ray energies are 75keV and 150keV (filtered)
- Measures  $Z_{\text{eff}}$  (effective atomic number) to  $<0.1$  (area average)
- Back scatter helps detecting sheet explosive
- Throughput can be over 1000 bags per hour (0.5m/s)
- Systems with 3~4mm pixel size have been very successful.
- False (positive) alarm is attributed to:
  - overlapping objects
  - Innocent material can have similar  $Z_{\text{eff}}$  as some explosives

# Single Energy X-Ray CT for Checked Bags

- Planer or helical CT provides 3-D image (165 keV x-ray typically)
- Detection decision is based on density and total mass.
  - <2% voxel noise (up to 250mm water)
  - Measures density to ~1%; (~2% drift with 250mm water)
- Throughput is several hundred bags per hour
- Systems with >3mm voxel size have been very successful.
- False (positive) alarm is mainly attributed to:
  - Innocent material can have similar density as some explosives
  - At same image quality, false alarm rate grows linearly with bag volume
- Dual energy CT has been developed and certified

# Air Cargo: Challenges with Increased Size

- More penetrating (higher energy, weaker interacting) x-ray means reduced intrinsic measurement sensitivity;
- Material signature with higher energy x-rays is also much weaker;
- Scatter of higher energy x-ray in larger objects adds complication;
- Automatic detection at LD3 size is near impossible with x-ray radiography due to complex overlapping—CT might be necessary.



# RF Linac Based High Energy X-Ray Sources

- Commercial high energy (MV) x-ray sources are based on electron Bremsstrahlung.
- The electron accelerator is usually an RF Linac.
- Side coupled standing wave structure is the most common.

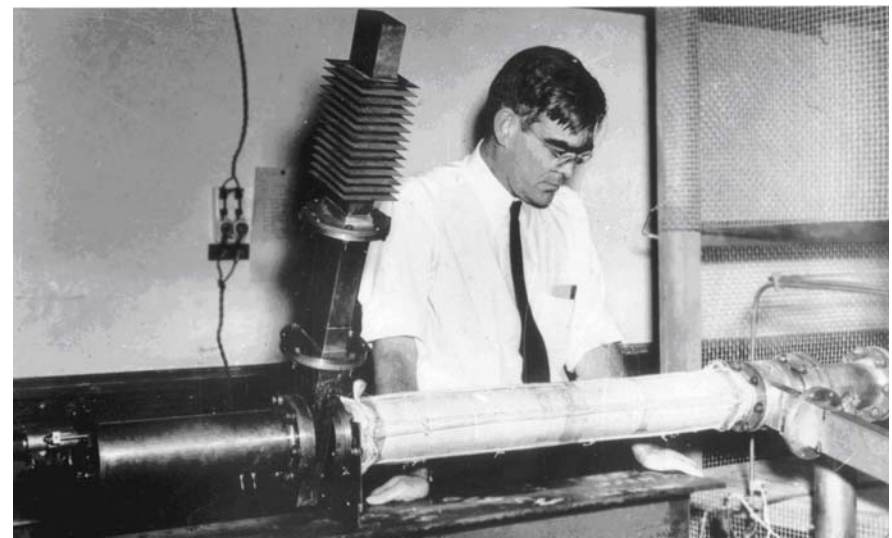

# Varian Linatron K-15A

- Beam energy: up to 15MV
- Dose rate: up to 15,000 rad/min at 1m
- By product: neutron
- RF structure: S-band/SW/side coupling
- RF source: 5.5MW klystron
- Typical use: inspecting large rockets



K-15 X-ray head

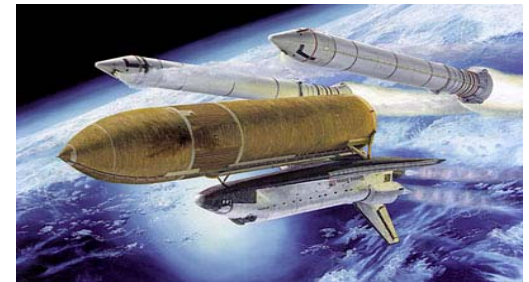



# Varian M-Series Linatrons

- M9/Mi9: 6-9MV, up to 3,000 rad/min at 1m
  - M6/Mi6: 3-6MV, up to 800rad/min at 1m
  - M3: 1-4.5MV, up to 300rad/min at 1m
  - RF structure: S-band/SW/side coupling
  - RF source: 2.6MW magnetron
- 
- M-series Linatrons are widely used in cargo inspection and NDT, with 1k+ units in service.
  - **Mi6, interlacing between 6MV and 4MV, is the standard source for cargo inspection.**

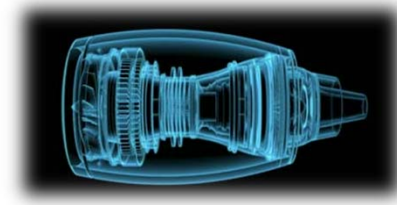
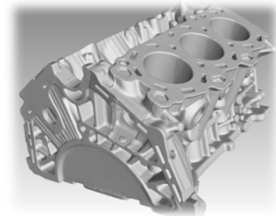

# Varian CX1/NX1/PX1 Linatrons

- Beam energy: 1MV
- Dose rate: 3 rad/min at 1m
- RF structure: X-band/SW/center coupling
- RF source: 380kW magnetron

## Typical uses:

- Law enforcement and special operations
- War zone security (Iraq and Afghanistan)



# High Energy X-Ray Detectors in Cargo Inspection

- Detectors are usually CWO or CSI scintillators coupled to photo diodes.
- Photo diodes usually work in photovoltaic mode to minimize noise.
- Linear array is the most common in cargo inspection.
- Scintillation distribution changes through the beam path. Such change is x-ray energy dependent, providing a means for energy sensitive imaging detector (layered detectors).

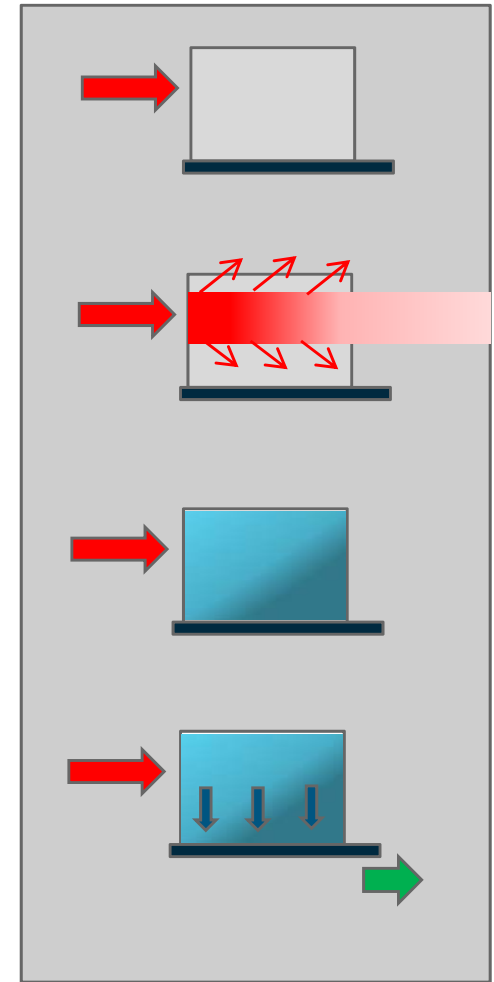

# Detectors: Pixel, Module and Array



# Measuring Effective Z with Dual-Energy X-Ray

- Various materials have different energy dependence in attenuation.
  - Photoelectric effect and pair production cross sections are  $Z$  dependent;
  - Compton scattering cross section is  $A/Z$  (electron density) dependent;
- Ratio of HiE and LoE attenuation contains material information ( $Z_{\text{eff}}$ );

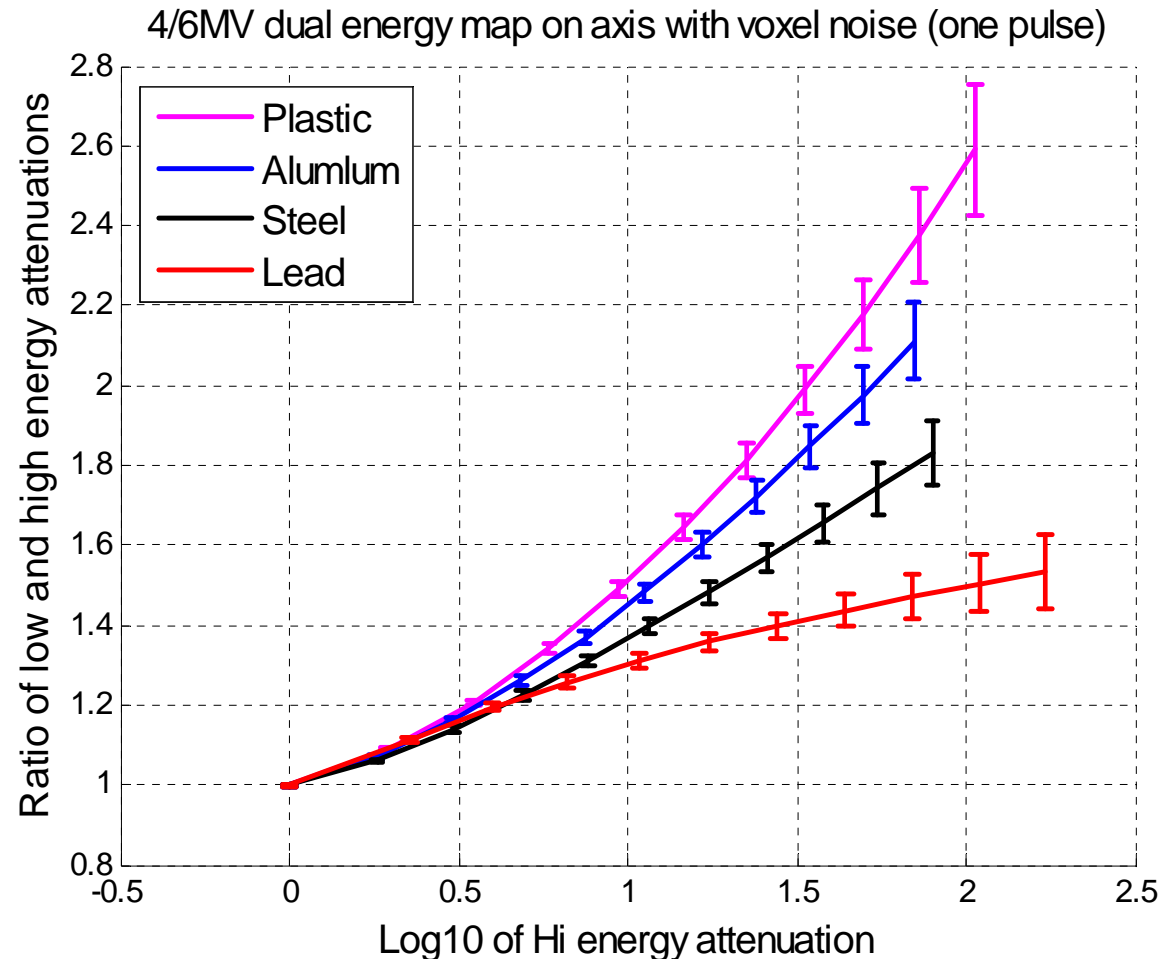

# Effective Z: Virtual Peeling with Radiography

2.75" Steel

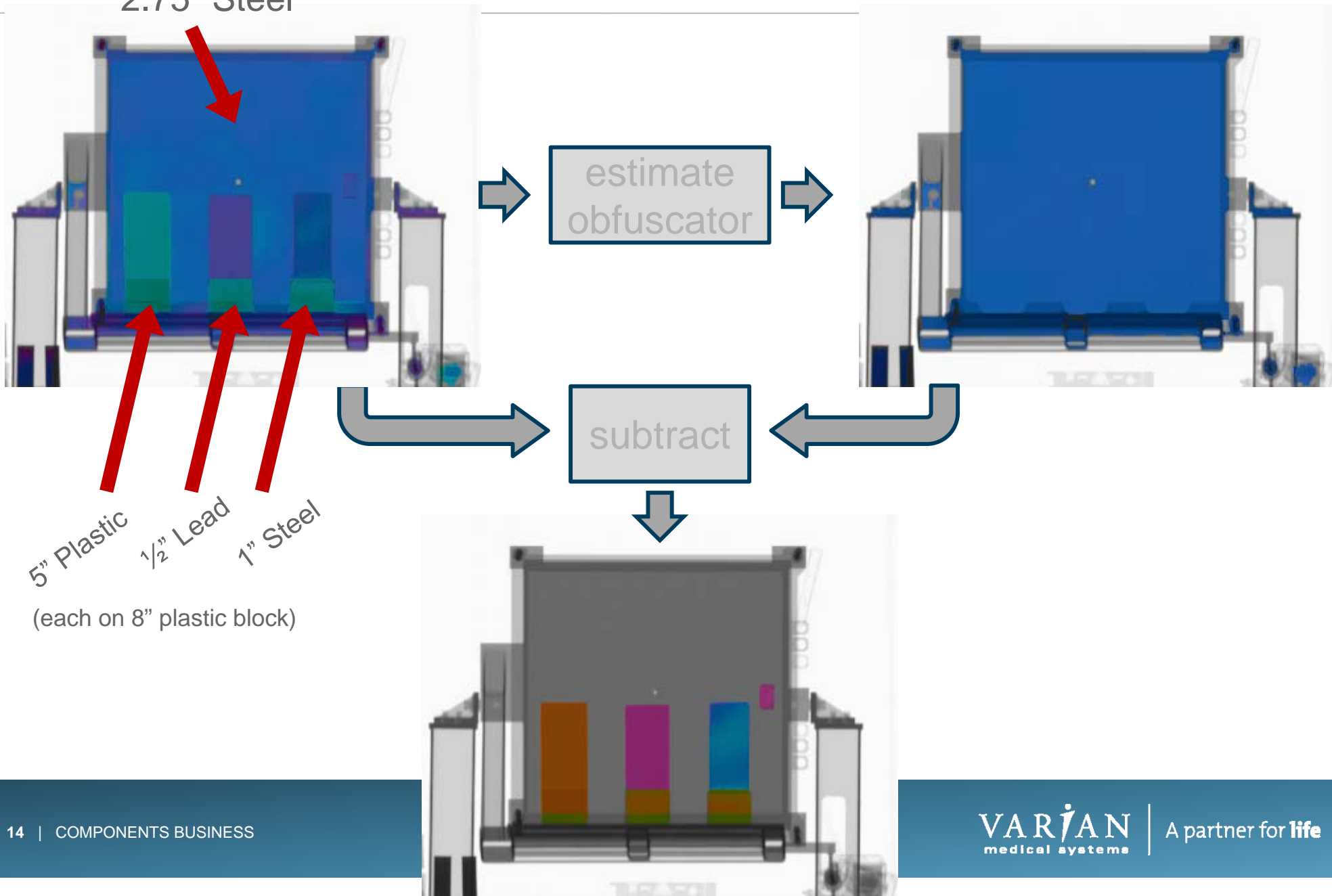



# Effective Z: Virtual Peeling with Radiography

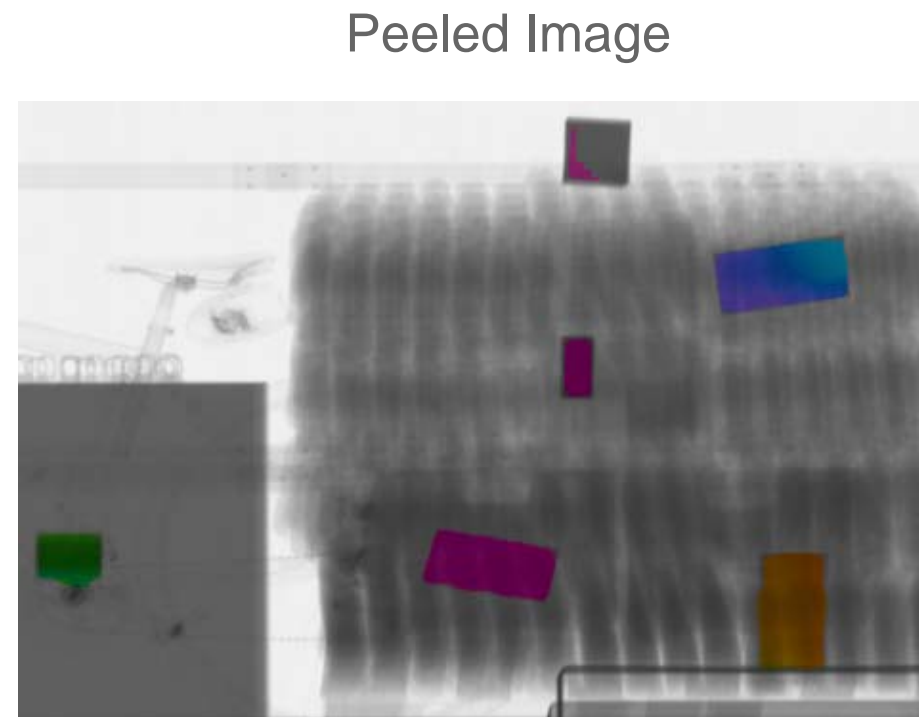
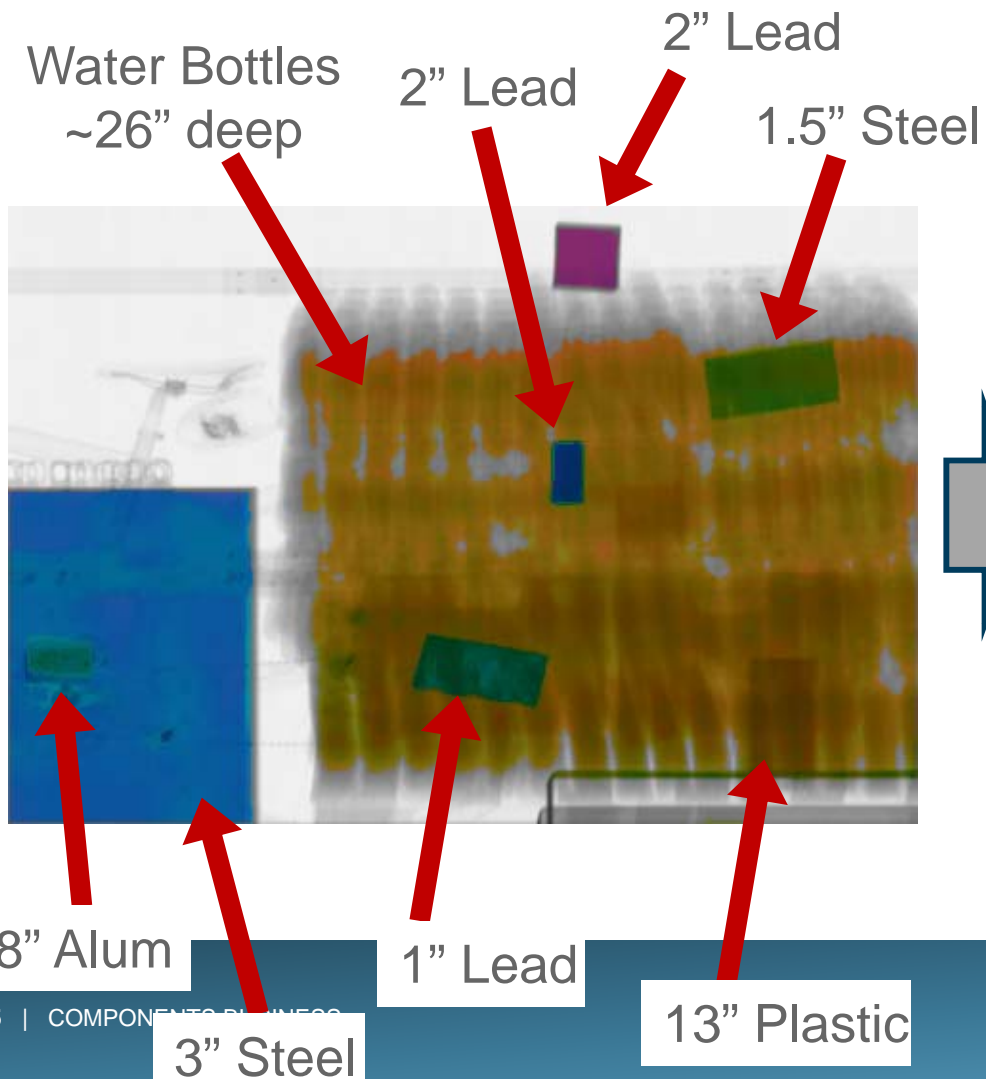

# Effective Z with Mi6 & Energy Sensitive Detectors

Dual Energy +  
conventional detectors

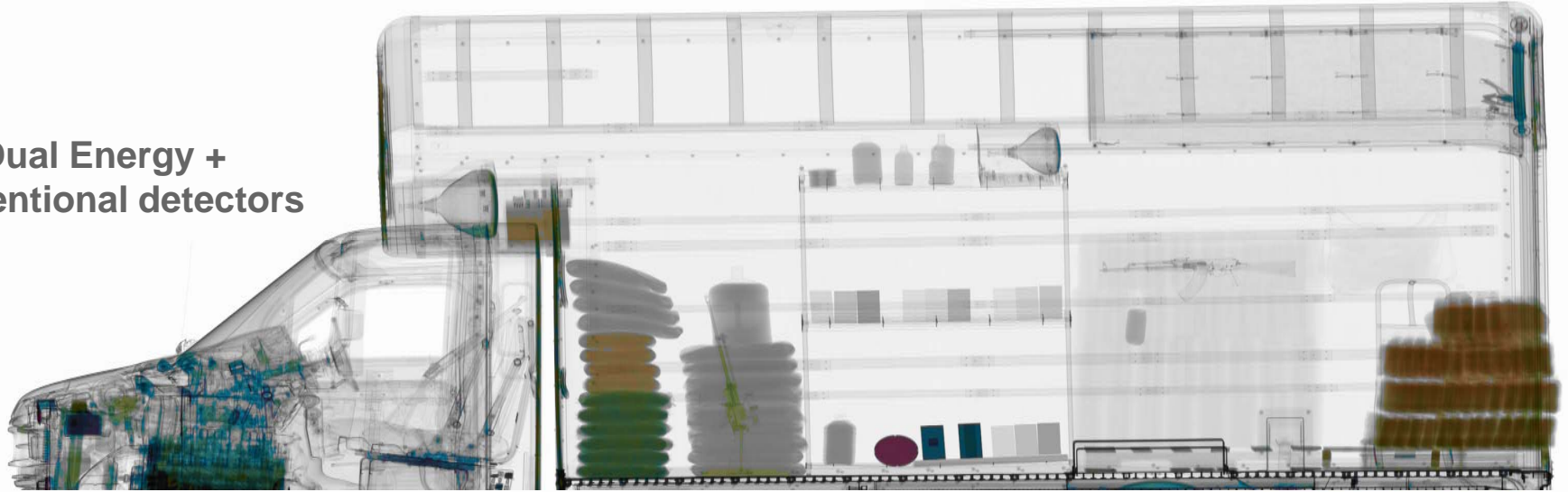

Dual Energy +  
energy sensitive detectors





# Tomography for Air Cargo

- Although layer peeling sounds encouraging, a fully loaded air cargo container is hopelessly complicated for algorithms fed with only radiographs.
- A 9MV (single energy) CT was built with TSA funding.
- The system has been used in automatic explosive detection algorithm development.
- Only density map is available.

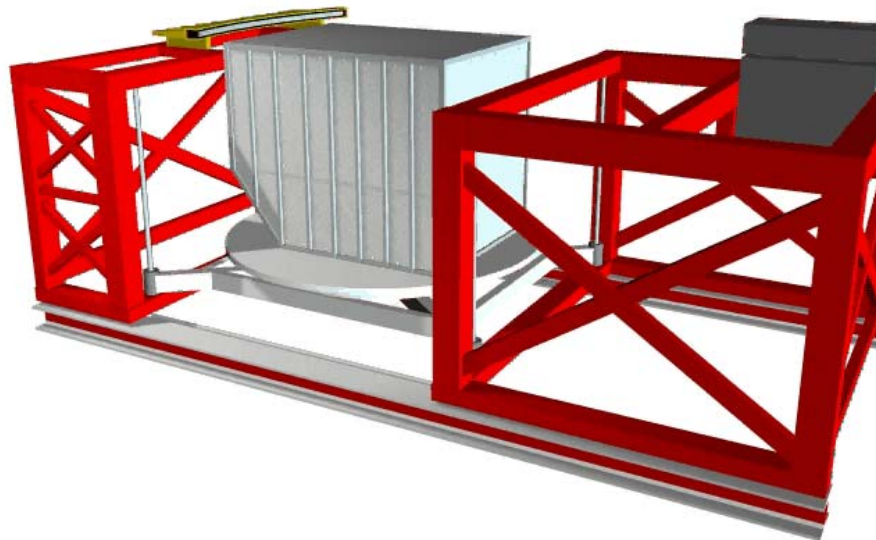

# 6/4MV Air Cargo CT Concept

- 6/4MV interlaced dual energy x-ray source
- 24 rows of detectors on helical pattern
- 3mm voxel size (900x900 array per rearranged slice)

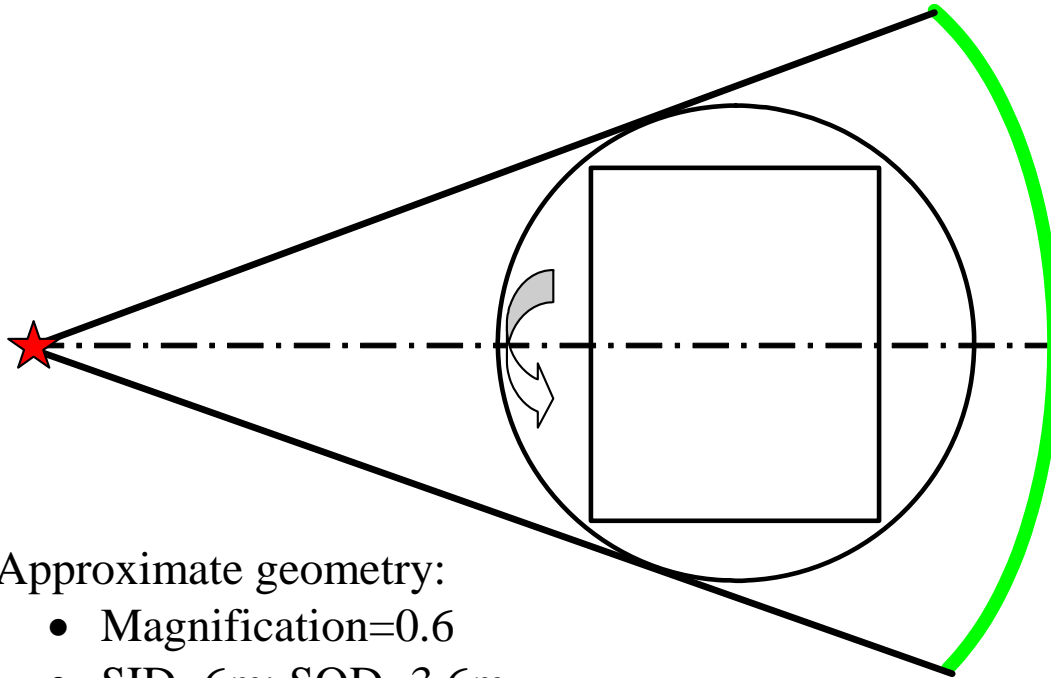

Approximate geometry:

- Magnification=0.6
- SID=6m; SOD=3.6m
- Fan angle=43°
- FOV=2.7m
- Horizontal plane

# 6/4MV Air Cargo CT Performance Goals

---

- Throughput >20 LD3 containers per hour ( <2 minute scan time)
- 3mm voxel size (2 voxel layers in sheet explosives)
- Voxel noise at 100g/cm<sup>2</sup> in primary (HiE) image: ~3%
- Voxel based Zeff accuracy (up to 100g/cm<sup>2</sup>): ~2
- Volume averaged Zeff (up to 100g/cm<sup>2</sup>): 0.2-0.3
- Volume averaged density accuracy (up to 100g/cm<sup>2</sup>): 1%-1.5%
- Automated detection of <100% threat quantity in LD3 containers.

# A New High Energy X-Ray Source

- CX1/PX1 at 1MV, 3rad/min works for air cargo radiography. CT with this source would be too slow.
- A new 1.6MV, 20rad/min source is being developed and will be available in 2015.
- One target use is air cargo CT (pallet size).

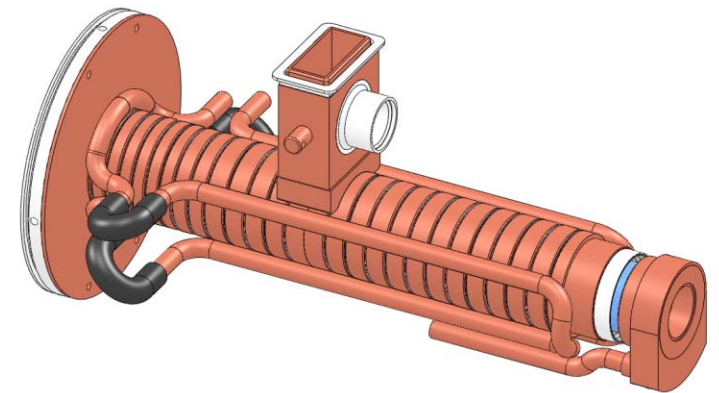
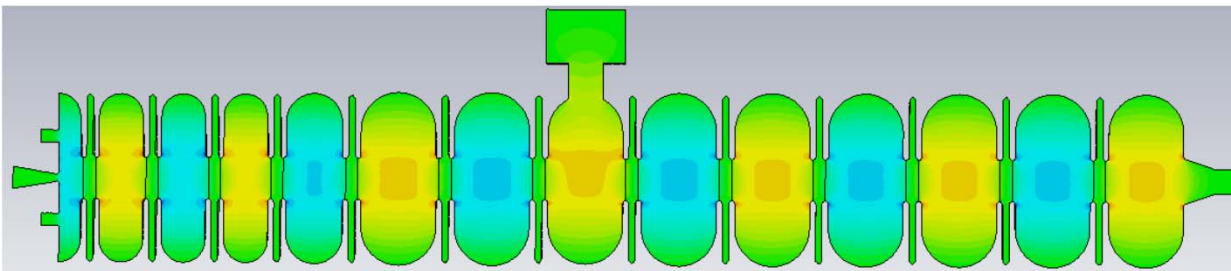

# New a-Si X-Ray Detectors for Cargo

- Detectors based on Varian's amorphous silicon technology are being developed.
- Detector is also segmented in depth direction and this adds spectral information.

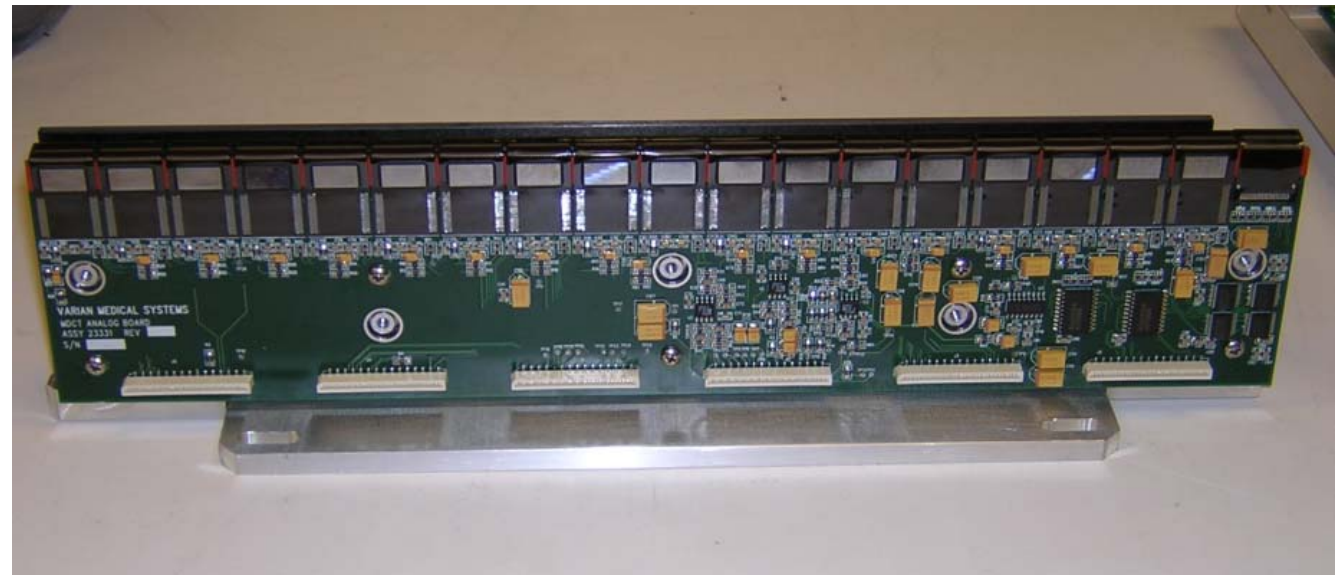
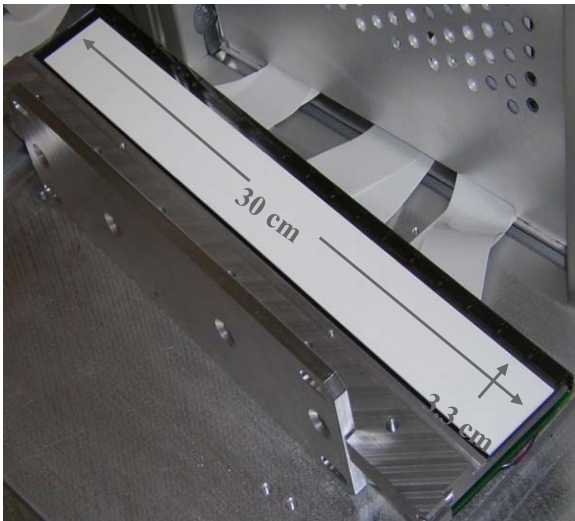

# HE (MV) Flat Panel Detector and correction algorithm

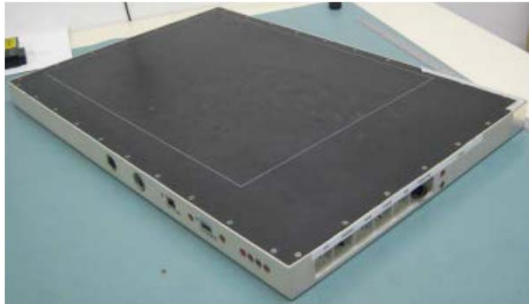

Only ring correction

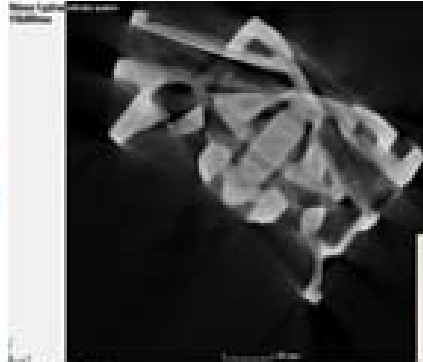

Beam Hardening, Scatter Correction, Lag Correction

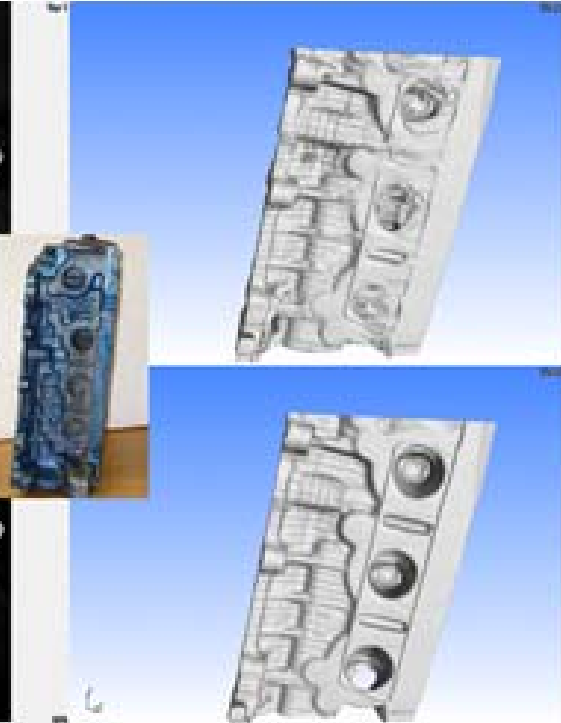
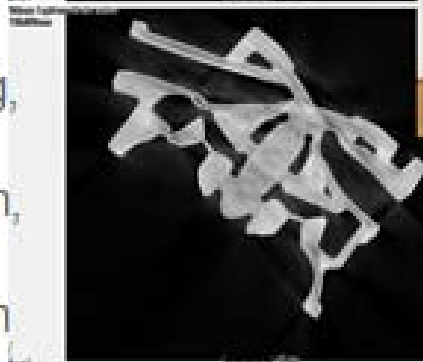

Attenuation ranges between 50 and ~1000

MV flat panel detector and correction algorithm, used with 1.6MV x-ray source, will be used in air cargo security.



# Flash Radiography Detectors

- Array is optimized for 20MV x-ray.
- Typical x-ray source has  $>5A$  electron beam current.
- Array works at 20,000,000 frames per second.
- Primary use is in weapon design (hydraulic test).

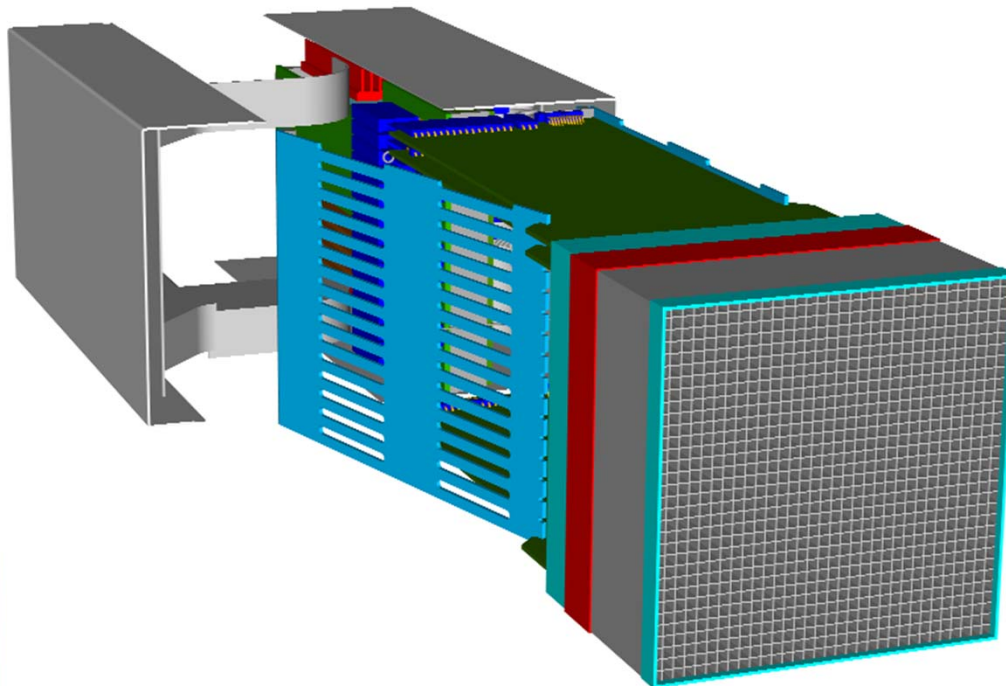

# Summary

---

- Appropriate high energy x-ray sources and detectors are available and systems can be built to facilitate automatic explosive detection in air cargo.
- Dual-energy x-ray CT feeds both density map and effective Z map to automatic explosive detection algorithm.
- New x-ray sources and detectors are in development.